

Hanfield

10506









Soft Twist
Double Knitting
81-137cm
32-54in

CARDIGAN in Hayfield SOFT TWIST

10506

MEASUREMENTS

Follow the pattern instructions for your size

Size	S	M	L	XL	XXL	XXXL
Chest 	81/86 cm 32/34"	91/97 cm 36/38"	102/107 cm 40/42"	112/117 cm 44/46"	122/127 cm 48/50"	132/137 cm 52/54"
Width 	102 cm 40"	113 cm 44½"	123 cm 48½"	134 cm 52¾"	142 cm 56"	153 cm 60¼"
Full Length 	54 cm 21¼"	56 cm 22"	58 cm 22¾"	60 cm 23¾"	62 cm 24½"	64 cm 25¼"
Sleeve Length 	48 cm 19"	48 cm 19"	49 cm 19¼"	50 cm 19¾"	50 cm 19¾"	50 cm 19¾"
Yarn* No Balls 	5	6	6	7	7	8
Buttons 	5	5	5	6	6	6
Yarn Button Ref You also need	F121 Hayfield Soft Twist, DK, 100g, shade 255 Mink Sirdar Elegant Button Code B5611-0785 1 Pair of 4mm (UK8 – USA6) Knitting Needles, 1 Pair of 3¼mm (UK10 – USA3) Knitting Needles and Stitch Holders.					

*Average number of balls required when you use the specified Hayfield yarn and tension shown below

TENSION & NEEDLES

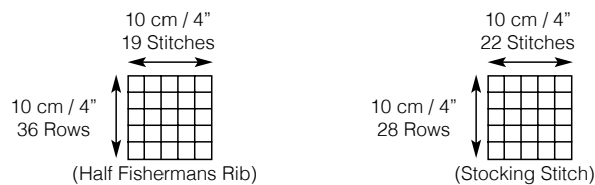

PIECE MEASUREMENTS

- A 51 [56.5:61.5:67:71:76.5] cm
(20 [22¼:24¼:26½:28:30¼])"
- B 54 [56:58:60:62:64] cm
(21¼ [22:22¾:23¾:24½:25¼])"
- C 24 [25:25:26:26:26] cm
(9½ [9¾:9¾:10¼:10¼:10¼])"
- D 27 [29:31:32:33:34] cm
(10¾ [11½:12:12½:13:13½])"
- E 9 [9:9:9:9] cm
(3½ [3½:3½:3½:3½])"
- F 19 [20:21:22:23:24] cm
(7½ [8:8¼:8¾:9:9½])"
- G 48 [48:49:50:50:50] cm
(19 [19:19¼:19¾:19¾:19¾])"
- H 48 [50:54:56:58:60] cm
(19 [19¾:21¼:22:22¾:23¾])"
- I 14 [15:15:16:16:16] cm
(5½ [6:6:6¼:6¼:6¼])"

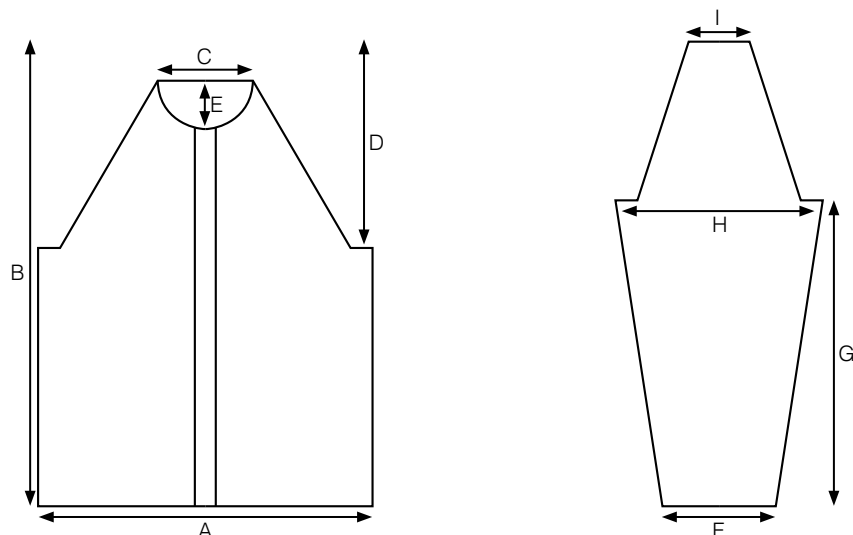

STITCHES & ABBREVIATIONS

alt - alternate

beg - beginning

cm - centimetres

cont - continue

dec - decrease(ing)

DK - double knitting

folll - following

g - grammes

in - inch(es)

inc - increase(ing)

k - knit

mm - millimetres

0 - no rows

p - purl

patt - pattern

psso - pass slipped stitch over

rem - remain(ing)

rep - repeat

rs - right side

s1 - slip 1 stitch knitways

st(s) - stitch(es)

tbl - through back of loop

tog - together

ws - wrong side

k1B - knit into stitch 1 row below stitch on needle.

BACK

Using 4mm needles and thumb method cast on 97 [107:117:127:135:145] sts.

1st Row. * K1, p1, rep from * to last st, k1.

2nd Row. P1, * k1, p1, rep from * to end.

1st and 2nd rows set **1x1 rib**.

Work in 1x1 rib for 8cm, (3in), ending with a ws row.

Proceed as follows:-

1st Row. Knit.

2nd Row. * P1, k1B, rep from * to last st, p1.

1st and 2nd rows set half fishermans rib.

Working in half fishermans rib as set (throughout) cont until back measures 27 [27:27:28:29:30]cm, (10³/₄ [10³/₄:10³/₄:11:11½:11¾]in), ending with a ws row.

Shape Raglan

Cast off 5 [5:5:6:6:6] sts in patt at beg of next 2 rows. 87 [97:107:115:123:133] sts.

1st Row. K2, s1, k1, psso, knit to last 4 sts, k2tog, k2. 85 [95:105:113:121:131] sts.

2nd Row. P3, patt to last 3 sts, p3.

3rd Row. Knit.

4th Row. P3, patt to last 3 sts, p3.

From 1st to 4th row sets raglan shapings. Work 60 [56:52:44:36:20] rows dec 1 st at each end as before in next and every foll 4th row.

55 [67:79:91:103:121] sts.

1st Row. K2, s1, k1, psso, knit to last 4 sts, k2tog, k2. 53 [65:77:89:101:119] sts.

2nd Row. P3, patt to last 3 sts, p3.

1st and 2nd rows set raglan shapings.

Work 8 [18:30:40:52:70] rows dec 1 st at each end as before in next and every foll alt row.

45 [47:47:49:49:49] sts.

Leave rem 45 [47:47:49:49:49] sts on a stitch holder.

LEFT FRONT

Using 4mm needles and thumb method cast on 46 [50:56:60:64:70] sts.

1st Row. * K1, p1, rep from * to end.

1st row sets rib.

Work in rib for 8cm, (3in), ending with a ws row.

1st Row. Knit.

2nd Row. K1, * p1, k1B, rep from * to last st, p1.

1st and 2nd rows set half fishermans rib.

Working in half fishermans rib as set (throughout) cont until left front measures 27 [27:27:28:29:30]cm, (10³/₄ [10³/₄:10³/₄:11:11½:11¾]in), ending with a ws row.

Shape Raglan

Cast off 5 [5:5:6:6:6] sts, knit to end.

41 [45:51:54:58:64] sts.

Next Row. Patt.

1st Row. K2, s1, k1, psso, knit to end. 40 [44:50:53:57:63] sts.

2nd Row. Patt to last 3 sts, p3.

3rd Row. Knit.

4th Row. Patt to last 3 sts, p3.

From 1st to 4th row sets raglan shaping. Work 60 [56:52:44:36:20] rows dec 1 st at raglan edge as before in next and every foll 4th row.

25 [30:37:42:48:58] sts.

1st Row. K2, s1, k1, psso, knit to end.

24 [29:36:41:47:57] sts.

2nd Row. Patt to last 3 sts, p3.

1st and 2nd rows set raglan shaping.

Work 1 [13:25:37:49:67] rows dec 1 st at

raglan edge as before in next and every foll 0 [2nd:2nd:2nd:2nd:2nd] row. 23 [22:23:22:22:23] sts.

Shape Neck

Next Row. Cast off 14 [15:16:16:

16:17] sts in patt, patt to last 3 sts, p3.

9 [7:7:6:6:6] sts.

Work 4 [2:2:2:2:2] rows dec 1 st at raglan edge as before in next and foll 2nd [0:0:0:0:0] row AT SAME TIME dec 1 st at neck edge in next and foll 2nd [0:0:0:0:0] row. 5 [5:5:4:4:4] sts.

For 1st, 2nd and 3rd sizes only

Work 2 rows dec 1 st at raglan edge only as before in next row. 4 sts.

For all 6 sizes

Leave rem 4 sts on a stitch holder.

RIGHT FRONT

Using 4mm needles and thumb method cast on 46 [50:56:60:64:70] sts.

1st Row. * P1, k1, rep from * to end.

1st row sets rib.

Work in rib for 8cm, (3in), ending with a ws row.

1st Row. Knit.

2nd Row. P1, * k1B, p1, rep from * to last st, k1.

1st and 2nd rows set half fishermans rib.

Working in half fishermans rib as set (throughout) cont until right front measures 27 [27:27:28:29:30]cm, (10³/₄ [10³/₄:10³/₄:11:11½:11¾]in), ending with a rs row.

Shape Raglan

Cast off 5 [5:5:6:6:6] sts in patt, patt to end. 41 [45:51:54:58:64] sts.

1st Row. Knit to last 4 sts, k2tog, k2. 40 [44:50:53:57:63] sts.

2nd Row. P3, patt to end.

3rd Row. Knit.

4th Row. P3, patt to end.

From 1st to 4th row sets raglan shaping.

Work 60 [56:52:44:36:20] rows dec 1 st at raglan edge as before in next and every foll 4th row.

25 [30:37:42:48:58] sts.

1st Row. Knit to last 4 sts, k2tog, k2.

24 [29:36:41:47:57] sts.

2nd Row. P3, patt to end.

1st and 2nd rows set raglan shaping.
Work 0 [12:24:36:48:66] rows dec 1 st at raglan edge as before in 0 [1st:1st:1st:1st:1st] and every foll 0 [2nd:2nd:2nd:2nd:2nd] row. 24 [23:24:23:23:24] sts.

Shape Neck

Next Row. Cast off 14 [15:16:16:16:17] sts, knit to last 4 sts, k2tog, k2. 9 [7:7:6:6:6] sts.

Next Row. P3, patt to end.

Work 4 [2:2:2:2:2] rows dec 1 st at neck edge in next and foll 2nd [0:0:0:0:0] row AT SAME TIME dec 1 st at raglan edge as before in next and foll 2nd [0:0:0:0:0] row. 5 [5:5:4:4:4] sts.

For 1st, 2nd and 3rd sizes only

Work 2 rows dec 1 st at raglan edge only as before in next row. 4 sts.

For all 6 sizes

Leave rem 4 sts on a stitch holder.

SLEEVES (Both alike)

Using 4mm needles and thumb method cast on 49 [53:55:57:59:63] sts.

Work in 1x1 rib for 12cm, (4³/₄in), ending with a rs row.

Next Row. P3 [2:5:2:6:1], inc in next st purlways, (p13 [15:3:3:2:3], inc in next st purlways) 3 [3:11:13:15:15] times, p3 [2:5:2:7:1]. 53 [57:67:71:75:79] sts.

1st Row. Knit.

2nd Row. Purl.

1st and 2nd rows set **st-st** (stocking stitch).

Working in st-st (throughout) proceed as follows:-

Next Row. Inc in each of first 2 sts, knit to last 3 sts, inc in each of next 2 sts, k1. 57 [61:71:75:79:83] sts.

Next Row. Purl.

Last 2 rows set sleeve increases.

Inc 2 sts at each end as before in next and every foll alt row to 81 [85:87:87:91:95] sts.

Inc 2 sts at each end as before in every foll

4th row to 105 [109:119:123:127:131] sts. Cont without shaping until sleeve measures 48 [48:49:50:50:50]cm, (19 [19:19¹/₄:19³/₄:19³/₄:19³/₄]in), ending with a ws row.

Shape Raglan

Cast off 5 [5:5:6:6:6] sts at beg of next 2 rows. 95 [99:109:111:115:119] sts.

1st Row. K2, s1, k1, pssso, knit to last 4 sts, k2tog, k2. 93 [97:107:109:113:117] sts.

2nd Row. P2, p2tog, purl to last 4 sts, p2togtbl, p2. 91 [95:105:107:111:115] sts. 1st and 2nd rows set raglan shapings.

Work 4 [2:6:4:4:6] rows dec 1 st at each end as before in every row. 83 [91:93:99:103:103] sts.

1st Row. K2, s1, k1, pssso, knit to last 4 sts, k2tog, k2. 81 [89:91:97:101:101] sts.

2nd Row. Purl.

1st and 2nd rows set raglan shapings.

Work 50 [56:58:62:66:66] rows dec 1 st at each end as before in next and every foll alt row.

31 [33:33:35:35:35] sts.

Cast off rem 31 [33:33:35:35:35] sts.

NECKBAND

Join raglan seams. With rs facing, using 3¹/₄mm needles pick up and knit 12 [13:14:14:14:15] sts evenly from 14 [15:16:16:16:17] cast off sts at right side of neck, 5 [4:4:3:3:3] sts evenly along right side of neck, knit across 4 sts left on a stitch holder at top of right side of neck, pick up and knit 23 [25:25:27:27:27] sts evenly from 31 [33:33:35:35:35] cast off sts at top of right sleeve, knit across 45 [47:47:49:49:49] sts left on a stitch holder at back of neck, pick up and knit 23 [25:25:27:27:27] sts evenly from 31 [33:33:35:35:35] cast off sts at top of left sleeve, knit across 4 sts left on a stitch holder at top of left side of neck, pick up and knit 5 [4:4:3:3:3] sts evenly along left side of neck and 12 [13:14:14:14:15] sts evenly from 14 [15:16:16:16:17] cast off sts at left side of neck.

133 [139:141:145:145:147] sts.

Starting with 1st row of 1x1 rib work in rib for 8cm, (3in), ending with 1st row.

Cast off in rib.

LEFT FRONT BORDER

With rs facing, using 3¹/₄mm needles pick up and knit 20 sts evenly along neckband, 96 [100:104:110:116:120] sts evenly along front edge and 21 sts evenly along rib.

137 [141:145:151:157:161] sts.

Starting with 2nd row of 1x1 rib work 11 rows.

Cast off in rib.

RIGHT FRONT BORDER

With rs facing, using 3¹/₄mm needles pick up and knit 21 sts evenly along rib, 96 [100:104:110:116:120] sts evenly along front edge and 20 sts evenly along neckband.

137 [141:145:151:157:161] sts.

Starting with 2nd row of 1x1 rib work 4 rows.

Next Row. Rib 4 [4:4:4:3:4], cast off 2 sts, rib 7 [7:7:7:9:7], cast off 2 sts, (rib 26 [27:28:23:24:25], cast off 2 sts) 4 [4:4:5:5:5] times, rib 4.

Next Row. Rib 5, cast on 2 sts, (rib 27 [28:29:24:25:26], cast on 2 sts) 4 [4:4:5:5:5] times, rib 8 [8:8:8:10:8], cast on 2 sts, rib 4 [4:4:4:3:4].

Work 5 rows more in rib.

Cast off in rib.

TO MAKE UP

Fold neckband in half onto ws and slip stitch loosely in position all around neck edge. Sew edges of neckband and blanket stitch around buttonhole. Join side and sleeve seams. Sew on buttons. Pin out garment to the measurement given. Cover with damp cloths and leave until dry. See ball band for washing and further care instructions.

QUERIES. Please contact:- Knitting Helpline. Sirdar Spinning Ltd. Flanshaw Lane, Wakefield. WF2 9ND. West Yorkshire, England.

For General Queries:- Tel: 01924 371501. Fax: 01924 290506.

For Knitting Helpline Enquiries:- Tel: 01924 231686. (Voice mail service replies within 7 working days) www.sirdar.co.uk • email: Knitting-helpline@sirdar.co.uk

WARNING. Reproduction of this publication is protected by copyright. It is sold on the condition that it is only used for non-commercial purposes.

All other rights reserved by Sirdar Spinning Ltd.

SIRDAR SPINNING LTD CANNOT ACCEPT RESPONSIBILITY FOR THE RESULT OF USING ANY OTHER YARN.

Owing to printing restrictions the colour reproduction is matched as closely as possible to the yarn. Printed in Great Britain.

SPJB10506



in	
cm	1
	2
	3
	4
	5
	6
	7
	8
	9
	10
	11
	12
	13
	14
	15
	16
	17
	18
	19
	20
	21
	22
	23
	24
	25
	26